

INSTALLATION, SERVICE AND MAINTENANCE INSTRUCTIONS

VERTICAL MIXER

ME-1100

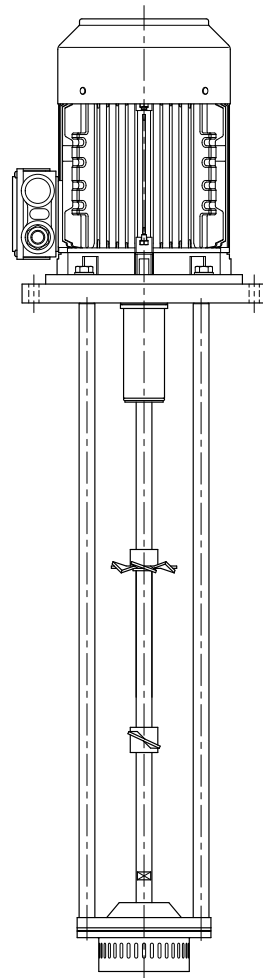

03.100.32.0011



Original Instructions

03.100.30.04EN

(B) 2024/08

EC Declaration of Conformity



INOXPA S.A.U.

Telers, 60
17820 - Banyoles (Spain)

hereby declare under our sole responsibility that the

Machine: **VERTICAL MIXER**

Model: **ME-1100**

Type: **ME-1101, ME-1103, ME-1105, ME-1110, ME-1125,
ME-1130**

Serial number: **IXXXXXXXXXX to IXXXXXXXXXX
XXXXXXXXXXIINXXX to XXXXXXXXXXXIINXXX**

fulfills all the relevant provisions of the following directive:

Machinery Directive 2006/42/EC
**Directive 2011/65/EU on the restriction of the use of certain hazardous substances
in electrical and electronic equipment**
Regulation (EC) n° 1935/2004
Regulation (EC) n° 2023/2006

and with the following harmonized standards and/or regulations:

EN ISO 12100:2010
EN 60204-1:2018
EN IEC 63000:2018

The technical file has been prepared by the signer of this document.

A handwritten signature in black ink, appearing to read "David Reyer Brunet".

David Reyer Brunet
Technical Office Manager
8th July 2024



Document: 03.100.30.05EN

Revision: (B) 2024/07

Declaration of Conformity



INOXPA S.A.U.

Telers, 60
17820 - Banyoles (Spain)

hereby declare under our sole responsibility that the

Machine: **VERTICAL MIXER**

Model: **ME-1100**

Type: **ME-1101, ME-1103, ME-1105, ME-1110, ME-1125,
ME-1130**

Serial number: **IXXXXXXXXXX to IXXXXXXXXXX
XXXXXXXXXXIINXXX to XXXXXXXXXXXIINXXX**

fulfils all the relevant provisions of these regulations:

Supply of Machinery (Safety) Regulations 2008
The Restriction of the Use of Certain Hazardous Substances in
Electrical and Electronic Equipment Regulations 2012 (as amended)

and with the following designated standards:

EN ISO 12100:2010
EN 60204-1:2018
EN IEC 63000:2018

The technical file has been prepared by the signer of this document.

A handwritten signature in black ink, appearing to be 'DR' or similar initials.

David Reyer Brunet
Technical Office Manager
8th July 2024

**UK
CA**

Document: 03.100.30.06EN
Revision: (A) 2024/07

1. Table of Contents

1. Table of Contents	
2. Generalities	
2.1. Instructions manual.....	4
2.2. Compliance with the instructions	4
2.3. Warranty.....	4
3. Safety	
3.1. Warning symbols.....	5
3.2. General safety instructions	5
4. General Information	
4.1. Description	7
4.2. Operating principle.....	7
4.3. Application.....	7
5. Installation	
5.1. Reception of the mixer	8
5.2. Identification of the mixer	8
5.3. Transport and storage.....	8
5.4. Location	9
5.5. Electrical installation	10
5.6. Assembly.....	10
6. Start-up	
7. Troubleshooting	
8. Maintenance	
8.1. General considerations	14
8.2. Maintenance	14
8.3. Lubrication	14
8.4. Spare parts	14
8.5. Conservation.....	14
8.6. Disassembly and assembly of the mixer.....	14
9. Technical Specifications	
9.1. Weights and dimensions	17
9.2. Sección técnica y lista de piezas	18
9.3. V-Ring sealing detail	20

2. Generalities

2.1. INSTRUCTIONS MANUAL

This manual contains information about the reception, installation, operation, assembly and maintenance of the ME-1100 vertical mixer.

Carefully read the instruction before starting the mixer, familiarize yourself with the installation, operation and correct use of the mixer and strictly follow the instructions. These instructions should be kept in a safe location near the installation area.

The information published in the instruction manual is based on updated data.

INOXPA reserves the right to modify this instruction manual without prior notice.

2.2. COMPLIANCE WITH THE INSTRUCTIONS

Not following the instructions may impose a risk for the operators, the environment and the machine, and may cause the loss of the right to claim damages

This non-compliance may cause the following risks:

- failure of important machine/plant functions,
- failure of specific maintenance and repair procedures,
- possible electrical, mechanical and chemical hazards,
- the risk to the environment due to the type of substances released.

2.3. WARRANTY

The conditions of the warranty are specified in the General Sales Condition that has been delivered at the time of placing your order.



The machine may not undergo any modification without prior approval from the manufacturer.

For your safety, only use original spare parts and accessories. The usage of other parts will relieve the manufacturer of any liability.

Changing the service conditions can only be carried out with prior written authorization from INOXPA.

The non-compliance of the prescribed indications in this manual means misuse of this gear on the technical side and the personal safety and this, exempt INOXPA of all responsibility in case of accidents and personal injuries and/or property damage. Also, excluded from the warranty all breakdowns caused by improper use of the gear.

Please do not hesitate to contact us in case of doubts or if further explanations are required regarding specific data (adjustments, assembly, disassembly, etc.).

3. Safety

3.1. WARNING SYMBOLS



Safety hazard for people in general and/or for the equipment



Electric hazard

ATTENTION

Important instruction to prevent damage to the equipment and/or its function

3.2. GENERAL SAFETY INSTRUCTIONS



Read the instruction manual carefully before installing and starting the blender. Contact INOXPA in case of doubt.

3.2.1. During installation

Always take into account the [Technical Specifications of chapter 9](#).

The installation and use of the mixer should always be in accordance with applicable regulations in regard to health and safety.

NEVER start-up the mixer before connect it to the tank.



Take all the precautions for move and assembly the mixer.

Before starting up the mixer, check that it is properly anchored and its shaft is perfectly aligned. Incorrect alignment and/or excessive stress during coupling can cause serious mechanical problems in the mixer.

Check the others installation components like tanks, valves, pipes, etc.

The mixer cannot work without liquid. The standards mixers are not designed to work during the fill or empty the tanks.



During the installation, all electric work should be carried out by specialised personnel. Keep the motor and the switchboard under control, particularly in areas where there is a risk of fire or explosion.

3.2.2. Durante operation

Always take into account the [Technical Specifications of chapter 9](#).

Under no circumstances can the specified limit values be exceeded.

Do not operate the mixer if turning components do not have a protection system or if they are badly fitted.



The mixer has rotating parts. Do not put hands or finger into the mixer when it is operating. Do not touch the parts of the mixer that are in contact with the fluid when in operation. When the mixer operates with hot fluids, temperatures above 50°C, there is a risk of skin burning. In such cases, collective-protection means (in this order of priority: separation, protective screen, heat-insulating material) or, in the absence of this, individual protection gear (gloves) must be used.

NEVER spray water directly on the electrical motor. The standard motor protection is IP55: protection against dust and water spray.



The mixers and their installation may cause noise levels that exceed 85 db(A) in some unfavourable operating environments. In such cases, operators should wear hearing protection.

3.2.3. During maintenance



Always take into account the [Technical Specifications of chapter 9](#).

Bear in mind that the product may be hazardous or extremely hot. Consult the regulations in effect in each country for these cases.

Do not leave loose parts on the floor.



ALWAYS disconnect the electrical power to the mixer prior to carrying out any maintenance.

Remove the fuses and disconnect the cable from the motor's terminals.

All electrical work must be carried out by authorized personnel.

4. General Information

4.1. DESCRIPTION

The ME-1100 series mixers are high shear vertical mixers that are mounted on the top part of the tank. To fix the mixer to the tank can be used a standard flange, a DIN 2632 PN10 flange or a rectangular flange.

The standard head is slotted but there are two others designs in case that the process required them. Circulating or down thrust propellers can be fitted to the shaft in order to increase the mixture or to create a vortex.

The shaft bottom part is guided by a bushing housed just above the head. Standard ones are supplied in PTFE but they may be made of other materials if the process required it.

The sealing system consists of a V-ring and it is driven by a direct motor.

The ME-1100 series is used in open and closed tanks operating at atmospheric pressure.

4.2. OPERATING PRINCIPLE

The rotor suctions the product from the lower part of the tank. After the product is suctioned, the product arrives at the rotor blades. The rotor blades push the product to the stator where it is sheared and then is expelled radially through holes stator at a high speed.

4.3. APPLICATION

The vertical mixers are suitable for the reduction of particles, dissolution, dispersion and emulsion process. They are suitable for his use in the food process.



The range of application for each type of mixer es limited. The mixer was selected for a given set of mixing conditions when the order was placed. INOXPA shall not be liable for any damage resulting from the incompleteness of the information provided by the purchaser (nature of the fluid, rpm, etc.).

5. Installation

5.1. RECEPTION OF THE MIXER



INOXPA cannot be held responsible for the damage sustained by the equipment during transport or unpacking. Please visually check that the packagin is not damaged.



If the mixer is supplied without drive or another element, the purchaser shall be responsible for its assembly, installation, start-up and operation.

The following documentation is included with the mixer:

- shipping documents,
- installation, service and maintenance instructions manual,
- instructions and service manual of the motor¹

1) if the mixer has been supplied with a motor from INOXPA

Unpack the mixer and check that is not damaged. If the equipment is not in good condition and/or any part is missing, the carrier should report accordingly as soon as possible.

5.2. IDENTIFICATION OF THE MIXER

Each mixer has a nameplate with the basic data required to identify the model:

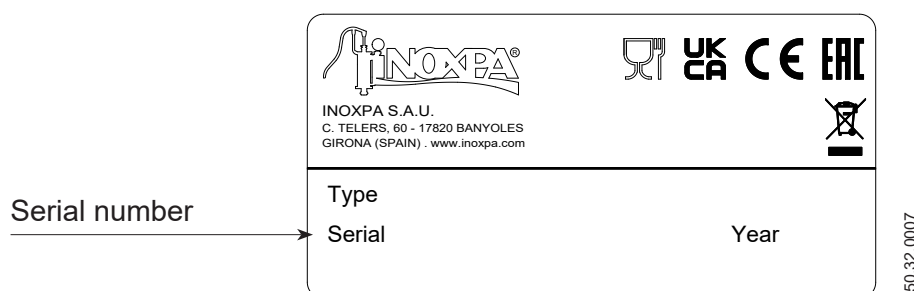

5.3. TRANSPORT AND STORAGE

ATTENTION



The mixers are often too heavy to be stored manually. Use an appropriate means of transport. Only authorized personnel should transport the blender. Do not work or walk under heavy loads.

Lift the mixer as indicated below:

- always use two support points placed as far apart as possible.

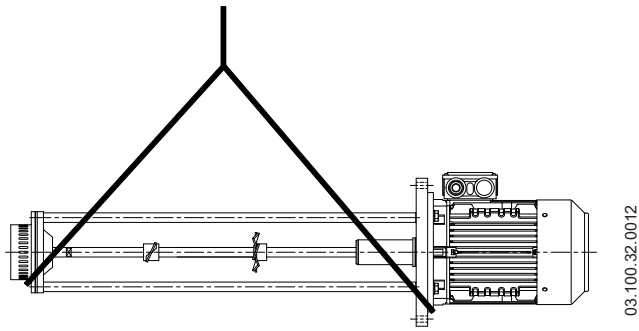

- secure the supports so that they will not move.

See chapter 9. [Technical Specifications](#) to consult the dimensions and weight of the mixer.

ATTENTION



During the transport, disassembly or assembly of the mixer, there is a risk of loss of stability and that the mixer could fall down and cause damages to the operators. Make sure that the mixer is properly supported.

If the mixer is not to be installed immediately, it must be stored in an appropriate place. It must be stored in a horizontal position and placed on wooden supports or for similar material. In this position, the shaft will not become deformed since it must not be subject to any type of load.

5.4. LOCATION

Place the mixer in such a way as to facilitate inspections and checks. Leave enough room around the mixer for service, disassembly and maintenance operations. It is very important to be able to access the electric connection device of the mixer, even when in operation.

To achieve a good mixing process is possible that it be necessary to place baffles in the tank. If this is the case, consult with INOXPA technical department for each specific application. If necessary, the approximate dimensions of the baffles according to the tank diameter are indicated in the next figure and the next table.

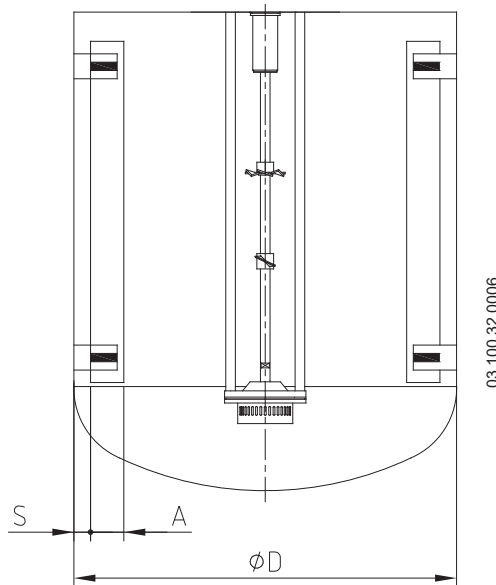

ØD	300	400	500	600	800	1000	1200	1600	2000	2500	3000	3500	4000
A	20	30	35	40	50	70	80	115	130	180	200	240	280
S	5	5	10	10	10	15	20	20	30	30	50	50	50

5.6.1. Excessive temperatures

Depending on the fluid to be mixed, high temperatures can be reached inside and around the mixer.



Over 68°C the operator should take protective measures and place warning notices advising of the danger which exists if the mixer is touched.
The type of protection selected should not isolate the mixer entirely.

5.5. ELECTRICAL INSTALLATION



All the electrical work must be performed by qualified personnel.
Take the appropriate measures to prevent any fault.
The motor must be provided with devices for protection against power overload and short-circuits.
The mixer cannot be used in areas where there is a risk of fire or explosion when this has not been specified in the order.

To do the electrical installation, connect the motor in accordance with the instructions supplied by the motor manufacturer following the current national legislation and in compliance with EN 60204-1.

5.6. ASSEMBLY

ATTENTION



Force should never be applied to the end of the mixer shaft, as it can easily suffer permanent damage.

In order to assure a good mixing process, the mixer should be positioned at a point corresponding to 1/3 of the tank diameter. Moreover, the distance from the mixer head to the bottom of the tank must be between 2 and 3 times the diameter of the head.

To do the assembly:

- place the mixer base onto the support flange,
- place the fixing screws and nuts to their corresponding holes, without being tightened,
- level the mixer,
 - put a spirit level up against the mixer shaft,
 - check four points at 90° to each other at which are at the same height,
- Tighten the fixing screws and nuts.

6. Start-up



Before starting the mixer, carefully read the instructions in chapter [5. Installation](#). Carefully read chapter [9. Technical Specifications](#). INOXPA will not be liable for improper use of the equipment.

- Check that the power supply matches the rating indicated on the motor plate.
- Check that the V-ring is not worn or damaged.
- Check the liquid level in the tank. The mixers cannot be operated during the filling or emptying of the tank. The mixing element has to be submerged to, at the very least, twice its diameter and must have clearance, with respect to the bottom, of 2 to 3 times the diameter of the head.



ATTENTION

The mixer must never turn dry.

- All the guards must be in place.
- The performance of the emulsifier mixer depends on the viscosity of the working fluid. The following loading process must be followed in order to use the mixer properly:
 - put all of the low viscosity components into the container,
 - start up the mixer,
 - check that the impeller turn in the right direction. It must turn clockwise as viewed from the drive side)



ATTENTION

Follow the direction of rotation of the mixing elements as indicated by the arrow attached to the engine. An incorrect direction of rotations results in a loss of mixer performance.



ATTENTION

Check the mixer direction of rotation since a wrong direction could cause a detachment of the pieces and later, its projection. This may cause personal damages and/or materials.

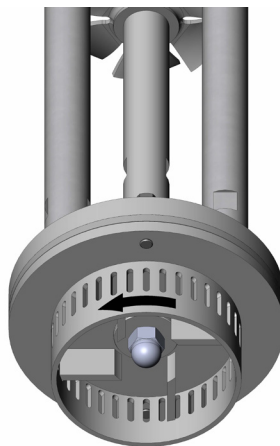

03.100.32.0007

- add the remaining liquids or soluble components,
 - add the solids that need to be cut or that need a pre-setting time to bring about the reaction,
 - add the remaining the components including the solids required to stabilise the formulation or the solids which are needed to increase the viscosity.
- Check the electrical consumption of the motor.

ATTENTION

Do not modify the operating parameters for which the mixer was initially designed without written authorisation from INOXPA. Risk of damage or user hazard could arise.

Follow the instructions for use and the safety requirements described in the instructions manual for the tank in which the mixer is mounted.

If the mixing element is accessible from the top of the tank inspections hatch, then the user will be exposed to mechanical risks like drag, shear, cutting, impact, flattening and pinching.

The tank must be fitted with protective devices and safety equipment. Consult the manufacturer's instructions manual.

ATTENTION

Introducing an object or solid raw material may cause the mixing component and other mechanical parts to break and compromise its safety or guarantee.

ATTENTION

Control the motor consumption to prevent an electrical overload.



Use special protection when the sound pressure in the operation area exceeds 85 dB(A).

7. Troubleshooting

The attached table lists solutions to problems that may arise while operating the mixer. It is assumed that the mixer has been properly installed and that it has been selected correctly for the specific application.

Contact INOXPA if technical assistance is required.

Motor overload		
Insufficient mixing		
Vibrations and noise		
Leaks		
	PROBABLE CAUSES	SOLUTIONS
• •	Viscosity of the liquid too high	Reduce the viscosity, e.g. by heating the liquid
•	High density	Increase motor power
• •	Tank too big for the chosen mixer	Check with the technical department
•	Wrong direction of rotation	Change direction of rotation
•	Mixer speed too low	Increase the speed
•	Liquid level insufficient or none	Check liquid level in the tank
•	Shaft bended	Replace the shaft
•	Critical speed	Check with the technical department
• •	Worn or damaged bushing	Replace the bushing
• •	Worn or damaged V-ring	Replace the V-ring
• •	The rotor is rubbing against the stator	Replace the bushing

8. Maintenance

8.1. GENERAL CONSIDERATIONS

This mixer, just like any other machine, requires maintenance. The instructions contained in this manual cover the identification and replacement of spare parts. The instructions are aimed at maintenance personnel and those responsible for the supply of spare parts.



Carefully read chapter 9. [Technical Specifications](#).
Maintenance work can only be carried out by qualified personnel that are trained and equipped with the necessary resources to carry out this work.
All parts or materials that are replaced must be properly disposed of/recycled in accordance with the current directives applicable in each area.



ALWAYS disconnect the mixer before beginning any maintenance work.



The symbol indicates that the product should not be discarded as unsorted waste but must be sent to separate collection facilities for recovery and recycling.

8.2. MAINTENANCE

- Inspect the mixer regularly.
- Do not fail to keep the mixer clean.
- Check the state of the motor.
- Check the V-ring.
- Check the bearing on completing every process. In the event of coming across excessive wear and tear, it must be changed.

Motor maintenance shall be carried out in accordance with the manufacturer's instructions, see the instructions manual.

8.3. LUBRICATION

The lubrication of the bearings of the motor will be carried out according to the manufacturer's instructions.

8.4. SPARE PARTS

To order spare parts is necessary to indicate the type and serial number included on the mixer's characteristics plate, as well as the position and description of the part as found in chapter 9. [Technical Specifications](#).

8.5. CONSERVATION

If the mixer is out of service for a considerable period of time, clean and treat the parts with VG46 mineral oil. The mixer must be stored in the horizontal position and on wooden supports or on supports of similar material. These supports will be situated on the mixer head.

8.6. DISASSEMBLY AND ASSEMBLY OF THE MIXER



The disassembly and assembly of the mixers should only be carried out by qualified personnel using only appropriate tools. Ensure that staff read these instructions manual attentively, particularly the instructions that relate to their work.



Stop the motor from starting up when carrying out assembly and disassembly work on the mixer.

Place the mixer switch in the “off” position.

Lockout the electrical switchboard or place a warning sign.

Remove the fuses and take them to the workplace.

8.6.1. Disassembly

Once the motor is disconnected, disassembly work may begin.

1. Disassemble the mixer from its emplacement.
2. Clean and dry the mixer.
3. In models ME-1101, ME-1105, ME-1110 and ME-1130, unscrew and retire the rotor.
4. In model ME-1125, remove the rotor nut (54) and retire the rotor. Then, you can retire the rotor pin (56A) from the extreme of the shaft.
5. Remove the hexagonal screws (52A) with their flat washers (53A) to retire the stator (22), the lower flange (42A) and the bushing (17) from the extreme of the shaft (05).
6. In case that the mixer has a down thrust propeller (02) and recirculation (02A) remove them unscrewing the allen setscrews (55B).
7. Remove the V-ring (81), the retaining ring (30) and the sleeve (13).
8. Remove the pin of the shaft (56) from the shaft complement (26) and remove the shaft (05).
9. Remove the hexagonal screws (52) with their flat washers (53) and remove the motor (93). The shaft complement (26) still will be fixed to the motor. Once the motor is removed, remove the O-rings (80) from the shaft complement (26) and then, remove the shaft complement (26) unscrewing the allen setscrews (55,55A).
10. In models ME-1101, ME-1105, ME-1110 and ME-1130, extract the countersunk screws (50) to separate the structural rods (29) from the upper flange (42).
11. In the model ME-1125, remove the countersunk screws (50) and the lock washers (53B) to separate the structural rods (29) from the upper flange (42).
12. Unscrew the structural rods (29) from the coupling flange (23).

8.6.2. Assembly

1. Screw the structural rods (29) to the coupling flange (23).
2. In the models ME-1101, ME-1105, ME-1110 and ME-1130, place the structural rods (29) to the upper flange (42) and fix them with the countersunk screws (50).
3. In the models ME-1125, place the structural rods (29) and the lock washers (53B) and fix them with the countersunk screws (50).
4. Place, onto the motor (93) shaft, the shaft complement (26) and fix it with the allen setscrews (55,55A)
5. Mount the motor (93) on the upper flange (42) and fix it with the hexagonal screws (52) and their flat washers (53).
6. Situate the shaft (05) in the internal part of the shaft complement (26). The correct situation of the shaft allows its fixation through the shaft pin (56).
7. Place the O-rings (80) on the shaft complement (26).
8. Mount the sleeve (13) on the shaft complement (26) placing the retaining ring (30) to avoid the displacement of the sleeve.
9. Place the V-ring following the next figure:

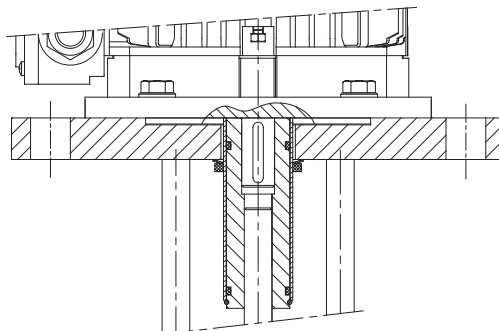

03.100.32.0010

10. In the case that the mixer has down thrust propellers (02) and recirculation (02A) place them on the shaft (05) in their corresponding situation and fix them with the allen setscrews (55B).
11. Place the lower flange (42A) and the stator (22) onto the coupling flange (23). These elements

- are fixed with the hexagonal screws (52A) and their flat washers (53A).
12. Slide the bushing (17) onto the shaft (05) until it reaches up to the lower flange (42A).
 13. In the model ME-1125, place the rotor pin (56A) in the hole of the extreme of the shaft.
 14. In the models ME-1101, ME-1105, ME-1110 and ME-1130, place the rotor (21) on the extreme of the shaft (05) and with a spanner place at the shaft interface to avoid it turning, screw the rotor (21).
 15. In the model ME-1125, face the rotor (21) in the rotor pin (56A), place the rotor washer (35) and fix the rotor with its nut (54).
 16. Mount the mixer in its emplacement.

9. Technical Specifications

Materials

Parts in contact with the product	1.4404 (AISI 316L)
Bushing	PTFE
V-ring	NBR

Mixer	Power (kW)	Speed (rpm)
ME-1101	1,1	3000
ME-1103	2,2	
ME-1105	4	
ME-1110	7,5	
ME-1125	18,5	
ME-1130	22	1500

9.1. WEIGHTS AND DIMENSIONS

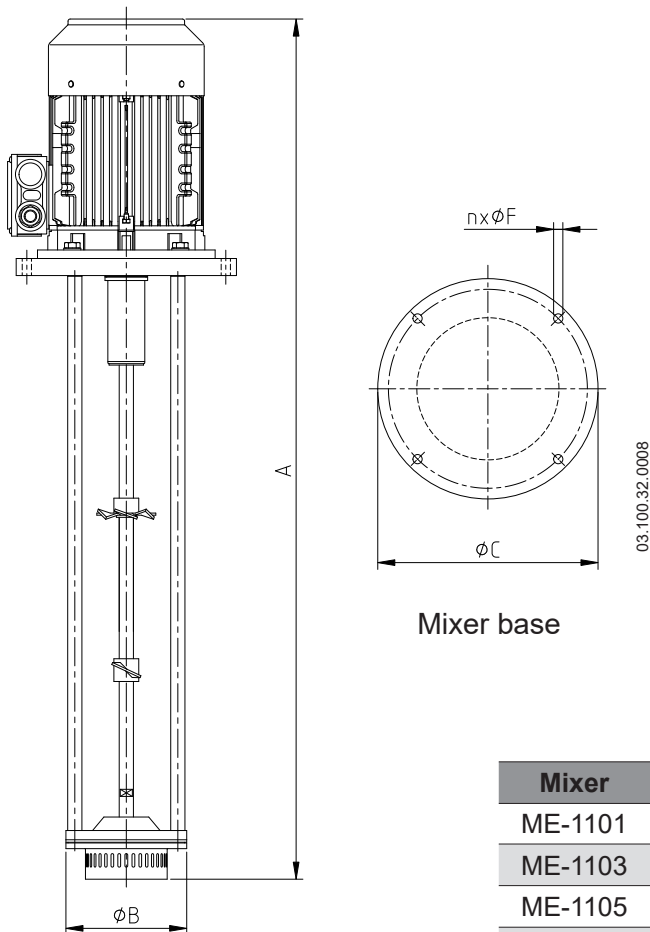

Mixer	A (mm)	ØB (mm)	ØC (mm)	Weight (kg)
ME-1101	1010	125	250	29
ME-1103	1080	125	250	36
ME-1105	1205	170	310	65
ME-1110	1660	185	360	115
ME-1125	1920	210	430	200
ME-1130	2080	290	430	350

9.2. TECHNICAL SECTION AND PARTS LIST

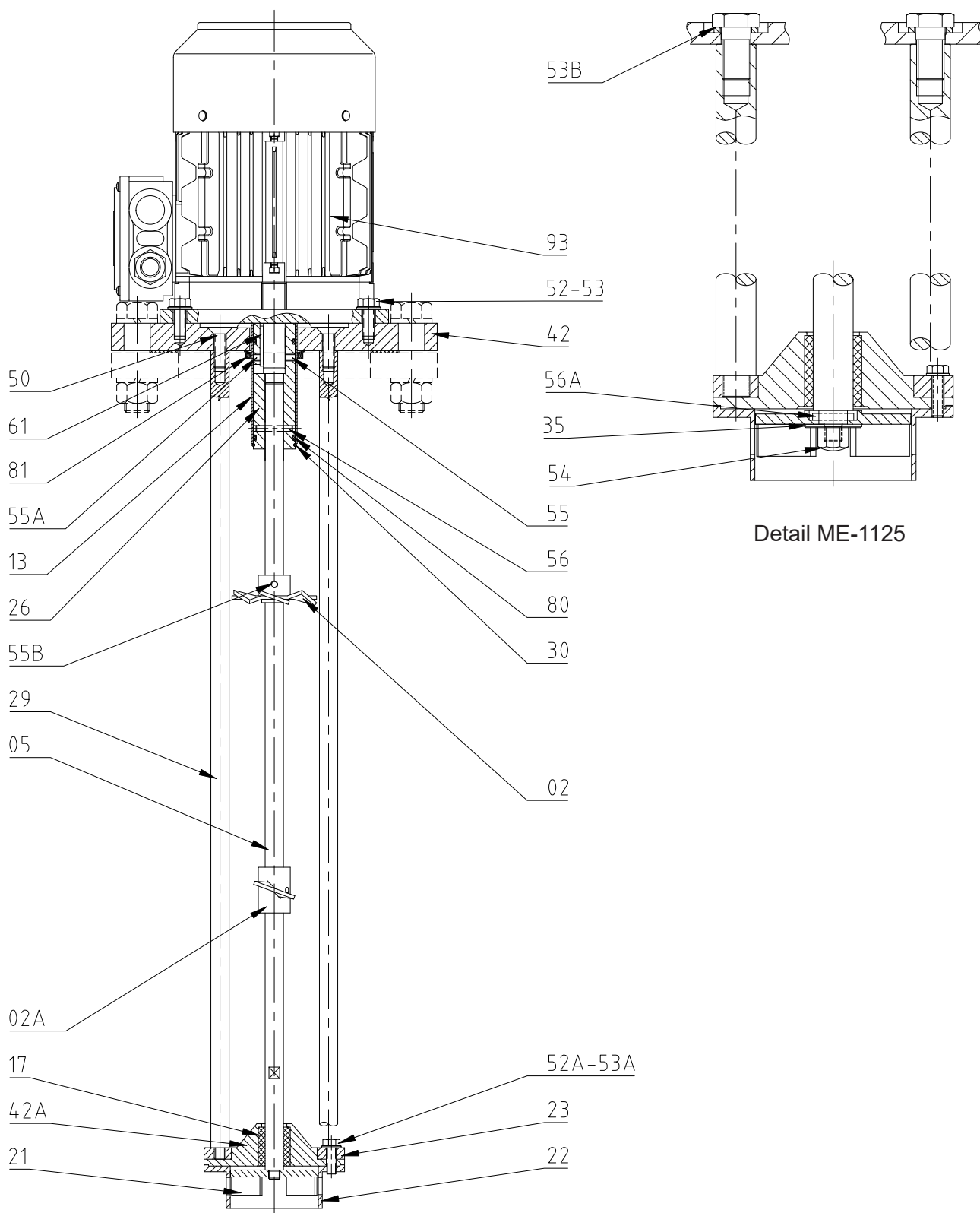

03.100.32.0009

Position	Description	Quantity	Material
02	downthrust propeller	1	1.4404 (AISI 316L)
02A	recirculation propeller	1	1.4404 (AISI 316L)
05	rotor shaft	1	1.4304 (AISI 316L)
13	coupling sleeve	1	1.4304 (AISI 316L)
17	bushing ¹	1	PTFE
21	rotor	1	1.4304 (AISI 316L)
22	stator	1	1.4304 (AISI 316L)
23	coupling flange	1	1.4304 (AISI 316L)
26	shaft complement	1	1.4304 (AISI 316L)
29	structural rod	4	1.4304 (AISI 316L)
30	retaining ring	1	1.4304 (AISI 316L)
35	rotor washer ²	1	A2
42	upper flange	1	1.4304 (AISI 316L)
42A	lower flange	1	1.4304 (AISI 316L)
50	countersunk screw	4	A2
52	hexagonal screw	4	A2
52A	hexagonal screw	2	A2
53	flat washer	4	A2
53A	flat washer	2	A2
53B	lock washer	4	A2
54	rotor nut	1	1.4304 (AISI 316L)
55	allen setscrew	3	A2
55A	allen setscrew	1	A2
55B	allen setscrew	2	A2
56	shaft pin	1	1.4304 (AISI 316L)
56A	rotor pin	1	1.4304 (AISI 316L)
80	O-ring ¹	2	NBR
81	V-ring ¹	1	NBR
93	motor	1	-

1) recommended spare parts

2) only in the model ME-1125

9.3. V-RING SEALING DETAIL

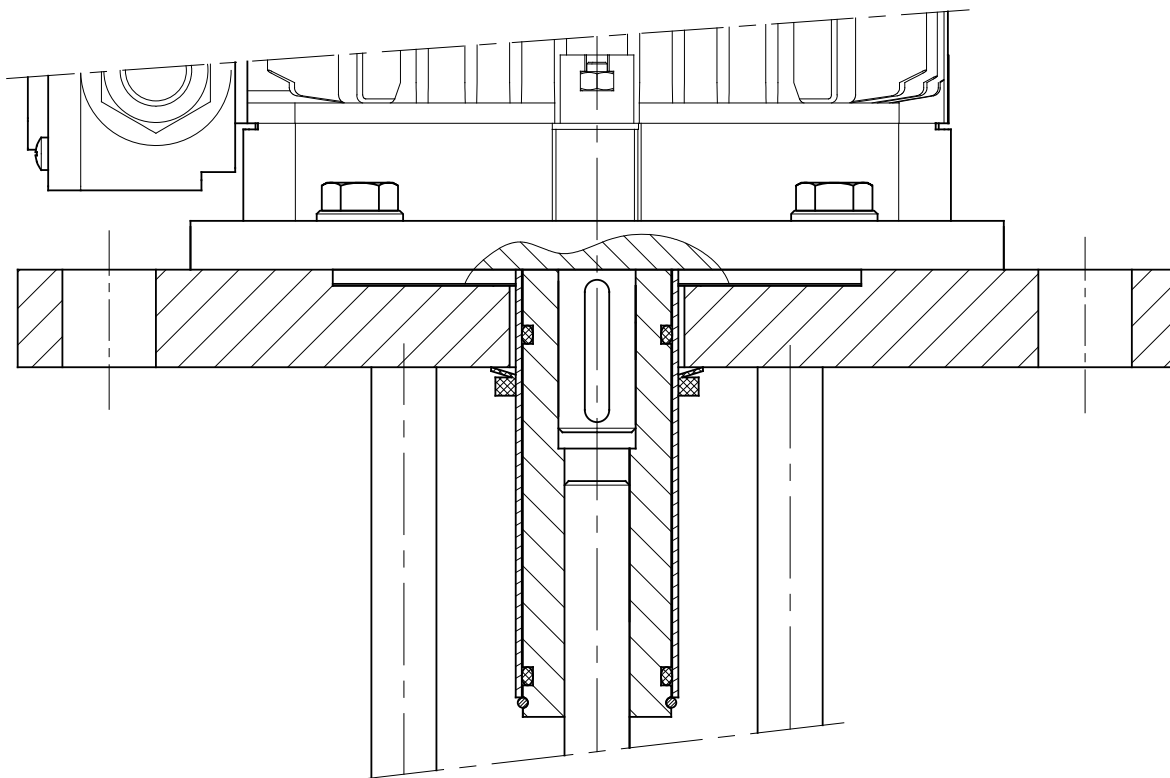

03.100.32.0010

NOTES

A series of horizontal lines for taking notes.

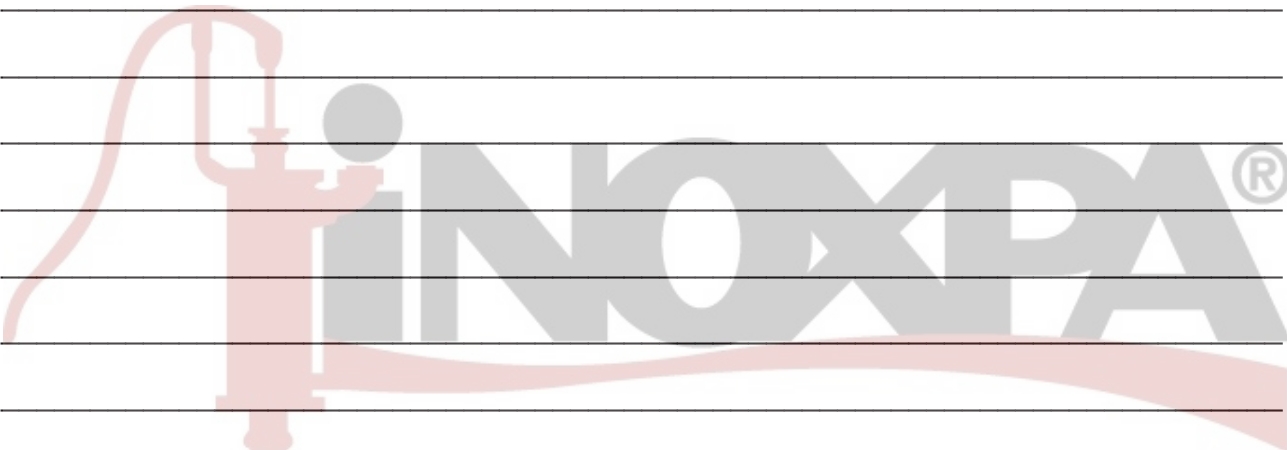

How to contact INOXPA S.A.U.:

Contact details for all countries are continually updated on our website.

Please visit www.inoxpa.com to access the information



INOXPA S.A.U.
Telers, 60 - 17820 - Banyoles - Spain

